

General Description

The LM321MFX brings performance and economy to low power systems. With a high unity gain frequency and a guaranteed 0.4V/μS slew rate, the quiescent current is only 80μA(5V). The input common mode range includes ground and therefore the device is able to operate in single supply applications as well as in dual supply applications. It is also capable of comfortably driving large capacitive loads.



Overall the LM321MFX is a low power, wide supply range performance op amp that can be designed into a wide range of applications at an economical price without sacrificing valuable board space.

The LM321MFX is available in the SOT23-5 package.

Features

- Gain-Bandwidth product 1MHz
- Low supply current 80μA(5V)
- Low input bias current 45nA
- Wide supply voltage range +3V to +36V

Package Information

| Part NO. | Package Description | Package Marking | Package Option |
|----------|---------------------|--------------------|----------------|
| LM321MFX | SOT23-5 | XLV XX LM321MFX | 3000/Reel |

XLV:Trademark

LM321MFX:Part NO.

Applications

- Chargers
- Power supplies
- Industrial controls and instruments
- Desktops
- Communications infrastructure

Block Diagram and Pin Configuration

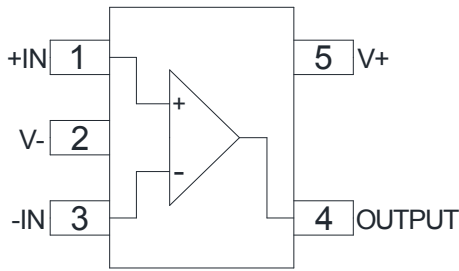

LM321MFX(SOT23-5)

Absolute Maximum Ratings *1

| Parameter Name | Value | Unit |
|--|------------|--------------|
| Supply Voltage | 36 | V |
| Input Voltage | -0.3~+36 | V |
| Output Short Circuit to GND $V^+ \leq 15V$ and $T_a=25^\circ C$ *2 | Continuous | |
| Junction Temperature *3 | 150 | $^\circ C$ |
| Thermal Resistance to Ambient (θ_{JA}) | 265 | $^\circ C/W$ |
| Operating Temperature Range | -40~+125 | $^\circ C$ |
| Storage Temperature Range | -65~+150 | $^\circ C$ |

Electrical Characteristics (Unless otherwise specified, $V^+ = 5.0V$)

| Parameter Name | Test Conditions | Min | Typ | Max | Unit | |
|---------------------------------|--|-------------|------|-------------|------|---------|
| Input Offset Voltage | $T_a=25^\circ C$ *4 | | 0.8 | 3 | mV | |
| Input Bias Current | $T_a=25^\circ C$, $I_{IN(+)}$ or $I_{IN(-)}$, $V_{CM}=0V$ *5 | | 45 | 150 | nA | |
| Input Offset Current | $T_a=25^\circ C$, $I_{IN(+)} - I_{IN(-)}$, $V_{CM}=0V$ | | 3 | 30 | nA | |
| Input Common-Mode Voltage Range | $T_a=25^\circ C$, $V^+ = 30V$ *6 | 0 | | $V^+ - 1.5$ | V | |
| Supply Current | Over Full Temperature Range, $R_L = \infty$ on all Op Amps | $V^+ = 32V$ | | 160 | 300 | μA |
| | | $V^+ = 5V$ | | 80 | 160 | |
| Large Signal Voltage Gain | $T_a=25^\circ C$, $V^+ = 15V$, $R_L \geq 2k\Omega$ (for $V_o = 1 \sim 11V$) | 50 | 100 | | V/mV | |
| Common-Mode Rejection Ratio | DC, $T_a=25^\circ C$, $V_{CM} = 0 \sim V^+ - 1.5V$ | 70 | 90 | | dB | |
| Power Supply Rejection Ratio | DC, $T_a=25^\circ C$, $V^+ = 5 \sim 30V$ | 75 | 100 | | dB | |
| Amplifier-to-Amplifier Coupling | $T_a=25^\circ C$, $f = 1 \sim 20kHz$ (input referred)*7 | | -120 | | dB | |

| Parameter Name | | Test Conditions | Min | Typ | Max | Unit |
|-------------------------|----------|---|-----------------|-----|-----|---------|
| Output Current | Source | $V_{IN(+)}=1V, V_{IN(-)}=0V, V^+=15V, V_o=2V, T_a=25^{\circ}C$ | 20 | 40 | | mA |
| | Sink | $V_{IN(-)}=1V, V_{IN(+)}=0V, V^+=15V, V_o=2V, T_a=25^{\circ}C$ | 10 | 15 | | mA |
| | | $V_{IN(-)}=1V, V_{IN(+)}=0V, V^+=15V, V_o=200mV, T_a=25^{\circ}C$ | | 50 | | μA |
| Short Circuit to Ground | | $T_a=25^{\circ}C, V^+=15V$ *2 | | 40 | 85 | mA |
| Output Voltage Swing | V_{OH} | $V^+=30V$ | $R_L=2k\Omega$ | 26 | | V |
| | | | $R_L=10k\Omega$ | 27 | 28 | V |
| | V_{OL} | $V^+=5V, R_L=10k\Omega$ | | 5 | 20 | mV |

* 1 Absolute Maximum Ratings indicate limits beyond which damage to the device may occur. Operating Ratings indicate conditions for which the device is intended to be functional, but specific performance is not guaranteed. For guaranteed specifications and the test conditions, see the Electrical Characteristics.

* 2: Short circuits from the output to V^+ can cause excessive heating and eventual destruction. When considering short circuits to ground, the maximum output current is approximately 40mA independent of the magnitude of V^+ . At values of supply voltage in excess of +15V, continuous short-circuits can exceed the power dissipation ratings and cause eventual destruction. Destructive dissipation can result from simultaneous shorts on all amplifiers.

* 3: The maximum power dissipation is a function of $T_{J(MAX)}$, θ_{JA} , and T_a . The maximum allowable power dissipation at any ambient temperature is $P_D = (T_{J(MAX)} - T_a) / \theta_{JA}$. All numbers apply for packages soldered directly onto a PC board.

* 4: $V_o=1.4V, R_s = 0\Omega$ with V^+ from 5V to 30V; and over the full input common-mode range (0V to $V^+ -1.5V$) at 25°C

* 5: The direction of the input current is out of the IC due to the PNP input stage. This current is essentially constant, independent of the state of the output so no loading change exists on the input lines.

* 6: The input common-mode voltage of either input signal voltage should not be allowed to go negative by more than 0.3V (at 25°C). The upper end of them common-mode voltage range is $V^+ -1.5V$ (at 25°C), but either or both inputs can go to +32V without damage, independent of the magnitude of V^+ .

*7: Due to proximity of external components, insure that coupling is not originating via stray capacitance between these external parts. This typically can be detected as this type of capacitance increases at higher frequencies.

Simplified Schematic

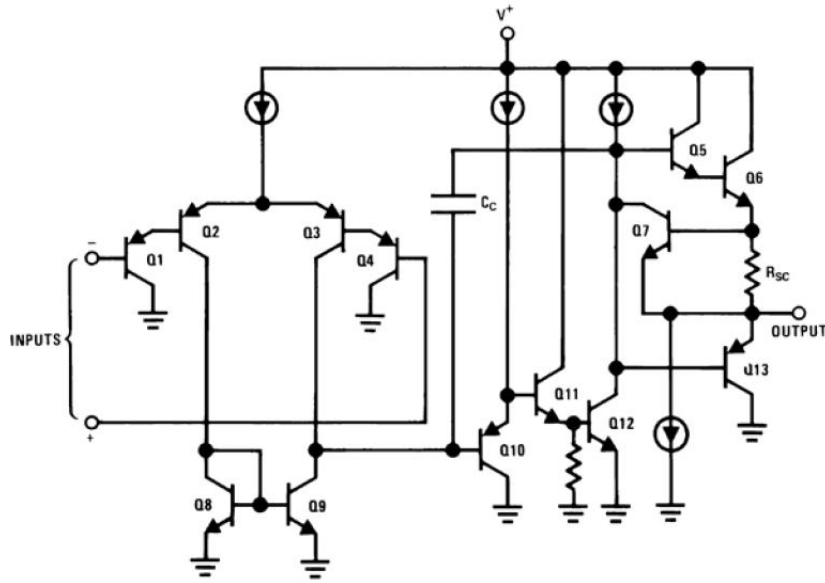

Typical Application

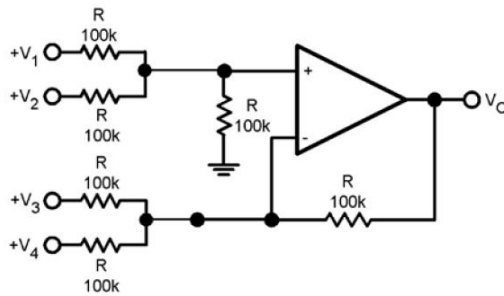

DC Summing Amplifier
 $(V_{IN's} \geq 0 \text{ } V_{DC} \text{ and } V_O \geq V_{DC})$

Where: $V_O = V_1 + V_2 - V_3 - V_4$, $(V_1 + V_2) \geq (V_3 + V_4)$ to keep $V_O > 0 \text{ } V_{DC}$

Non-Inverting DC Gain (0V Input = 0V Output)

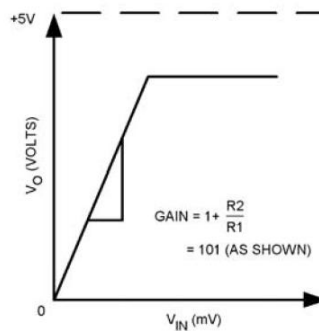
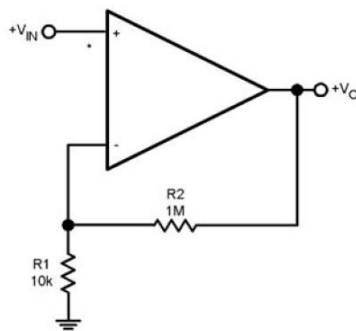

* R NOT NEEDED DUE TO TEMPERATURE INDEPENDENT I_{IN}

Amplitude Modulator Circuit

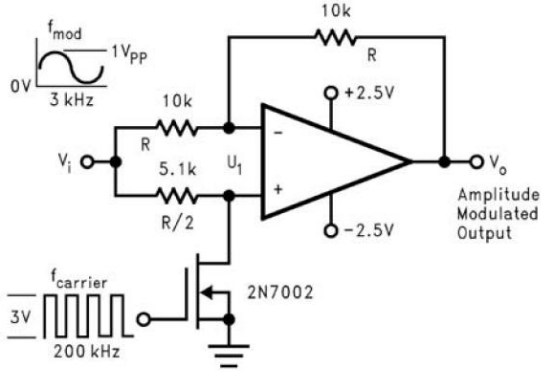

DC Summing Amplifier
($V_{IN's} \geq 0$ V_{DC} and $V_O \geq V_{DC}$)

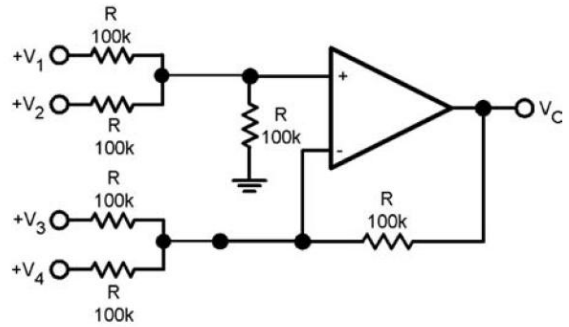

Where: $V_O = V_1 + V_2 - V_3 - V_4$, ($V_1 + V_2 \geq V_3 + V_4$) to keep $V_O > 0$ V_{DC}

Power Amplifier

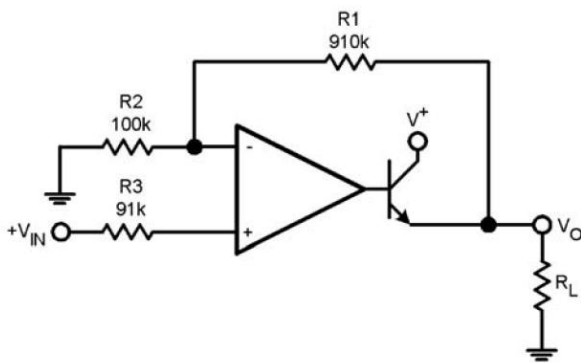

$V_O = 0$ V_{DC} for $V_{IN} = 0$ V_{DC} , $A_V = 10$

LED Driver

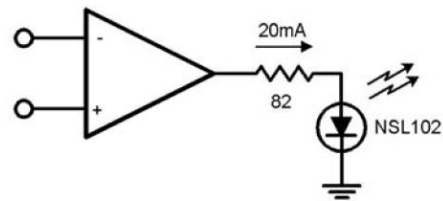

Fixed Current Sources

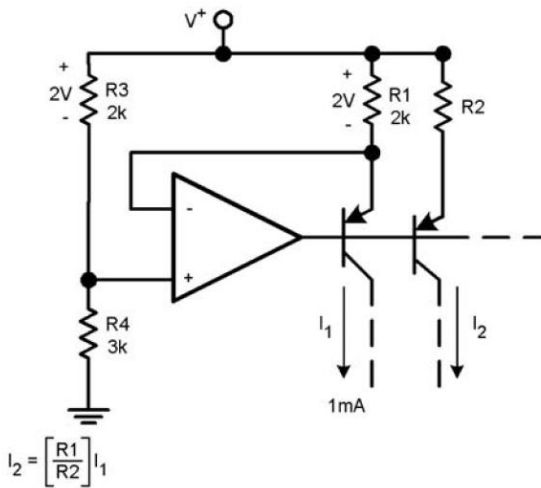

Lamp Driver

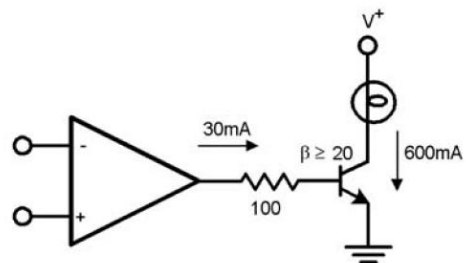

Application Summary

The LM321MFX op amp can operate with a single or dual power supply voltage, has true-differential inputs, and remain in the linear mode with an input common-mode voltage of 0 V_{DC} . This amplifier operates over a wide range of power supply voltages, with little change in performance characteristics. At 25°C amplifier operation is

possible down to a minimum supply voltage of 3V.

Large differential input voltages can be easily accommodated and, as input differential voltage protection diodes are not needed, no large input currents result from large differential input voltages. The differential input voltage may be larger than V^+ without damaging the device. Protection should be provided to prevent the input voltages from going negative more than $-0.3 V_{DC}$ (at 25°C). An input clamp diode with a resistor to the IC input terminal can be used.

To reduce the power supply drain, the amplifier has a class A output stage for small signal levels which converts to class B in a large signal mode. This allows the amplifiers to both source and sink large output currents. Therefore both NPN and PNP external current boost transistors can be used to extend the power capability of the basic amplifiers. The output voltage needs to raise approximately 1 diode drop above ground to bias the on-chip vertical PNP transistor for output current sinking applications.

For AC applications, where the load is capacitively coupled to the output of the amplifier, a resistor should be used, from the output of the amplifier to ground to increase the class A bias current and to reduce distortion.

Capacitive loads which are applied directly to the output of the amplifier reduce the loop stability margin. Values of 50pF can be accommodated using the worst-case non-inverting unity gain connection. Large closed loop gains or resistive isolation should be used if large load capacitance must be driven by the amplifier.

The bias network of the LM321MFX establishes a supply current which is independent of the magnitude of the power supply voltage over the range of from $3 V_{DC}$ to $30 V_{DC}$.

Output short circuits either to ground or to the positive power supply should be of short time duration. Units can be destroyed, not as a result of the short circuit current causing metal fusing, but rather due to the large increase in IC chip dissipation which will cause eventual failure due to excessive junction temperatures. The larger value of output source current which is available at 25°C provides a larger output current capability at elevated temperatures than a standard IC op amp.

The circuits presented in the section on typical applications emphasize operation on only a single power supply voltage. If complementary power supplies are available, all of the standard op amp circuits can be used.

In general, introducing a pseudo-ground (a bias voltage reference of $V^+/2$) will allow operation above and below this value in single power supply systems. Many application circuits are shown which take advantage of the wide input common-mode voltage range which includes ground. In most cases, input biasing is not required and input voltages which range to ground can easily be accommodated.

Characteristics Curves

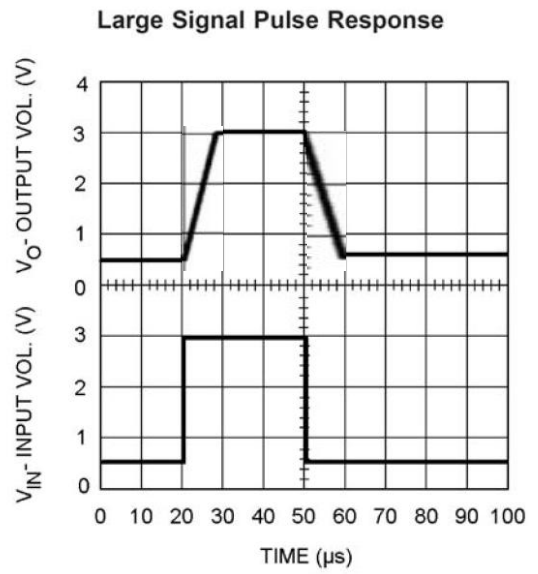
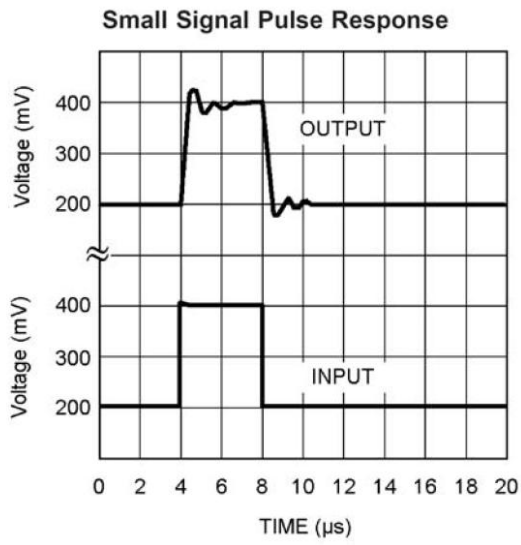

Outline Dimensions

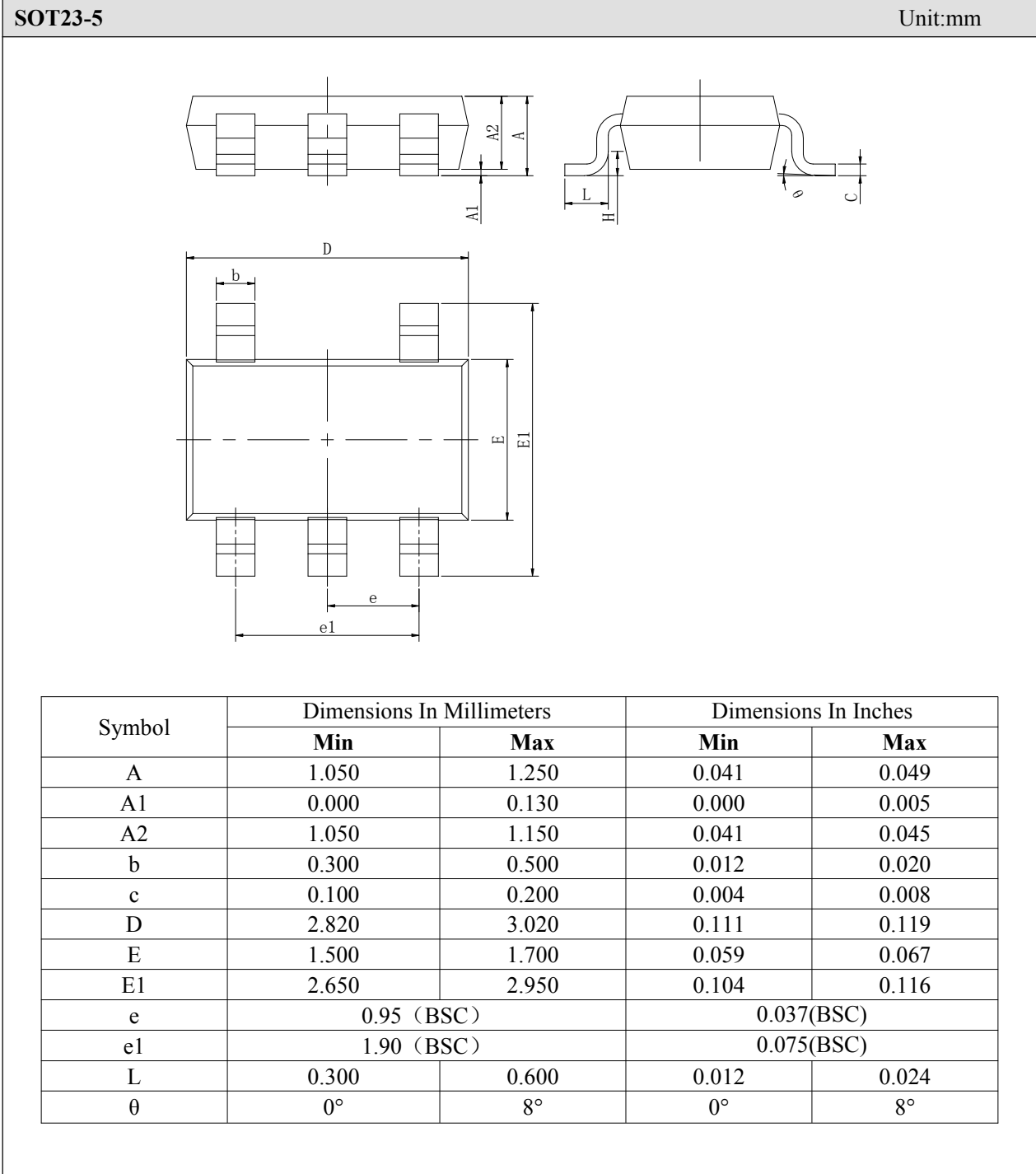

Statements

- XLV reserves the right to modify any products or specifications described in this document at any time without prior notice. Customers must confirm that the specification documentation obtained is the latest version and verify the completeness and accuracy of all information before placing orders.
- Any semiconductor product may fail or malfunction under specific conditions. When using XLV products for system design and machine manufacturing, customers must strictly comply with applicable safety standards and adopt all necessary safeguards to mitigate potential failure risks, thereby preventing personal injury or property damage.
- XLV will continuously pursue optimization of product performance and quality, striving to provide customers with superior integrated circuit solutions.
-